

CONCRETE BLOCK WALL - ABOVE GRADE

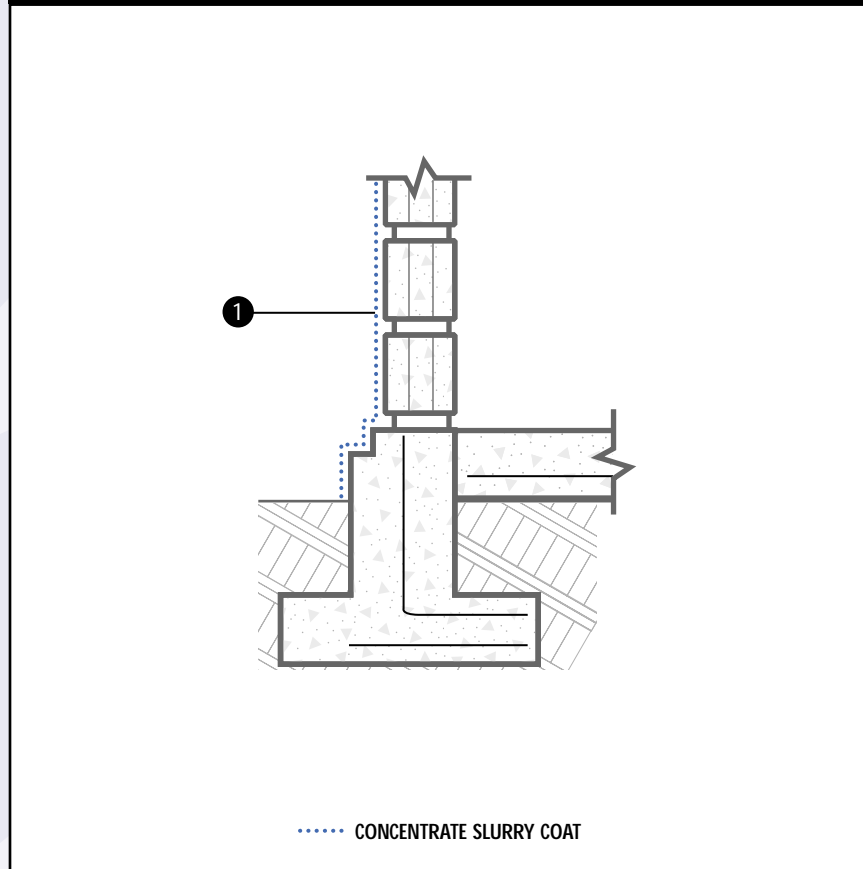

- ① Apply one slurry coat of Xypex Concentrate at the rate of 1.5 lb./sq. yd. (0.8 kg/m²). Coating should extend to ground level. Where poor quality block is encountered, a second coat of Xypex Concentrate should be applied at the rate of 1.25 to 1.5 lb./sq. yd. (0.65 to 0.8 kg/m²).

Note 1: Wall sections should be defined before application and each of these sections should be completed during the same day to obtain maximum uniformity in appearance.

Note 2: Because of the variances in the quality of concrete block (e.g. cement content, porosity, etc.), please consult your Xypex technical representative.

Schematic diagram shows Xypex application only and does not depict the standard requirements for waterstops or expansion joint sealants.

The specifier can consider the alternative use of Xypex Dry Shake or Xypex Admix, where applicable.

Refer to Standard Specifications for further information.