

STANDARD CONSTRUCTION JOINT DETAILS

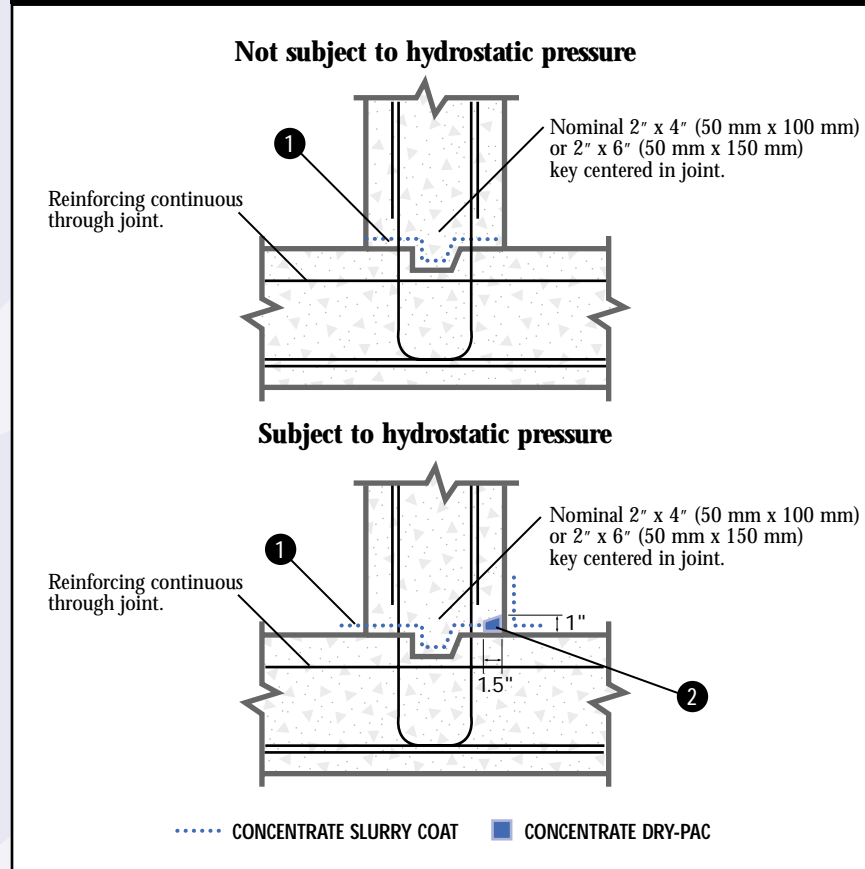

WALLS/SLAB INTERFACE

- ① **Joint Waterproofing:** Clean joint thoroughly. Between pours, apply Xypex Concentrate slurry to joint surfaces at the rate of 2.0 lb./sq. yd. (1.0 kg/m²).
- ② **Sealing Strip:** Clean pre-formed groove thoroughly. Apply Xypex Concentrate slurry to groove at the rate of 1.5 lb./sq. yd. (0.8 kg/m²). Fill groove with Xypex Concentrate Dry-Pac and pack tightly. Pre-formed groove may be offset to either side of joint.

Schematic diagram shows Xypex application only and does not depict the standard requirements for waterstops or expansion joint sealants.

The specifier can consider the alternative use of Xypex Dry Shake or Xypex Admix, where applicable.

Refer to Standard Specifications for further information.